

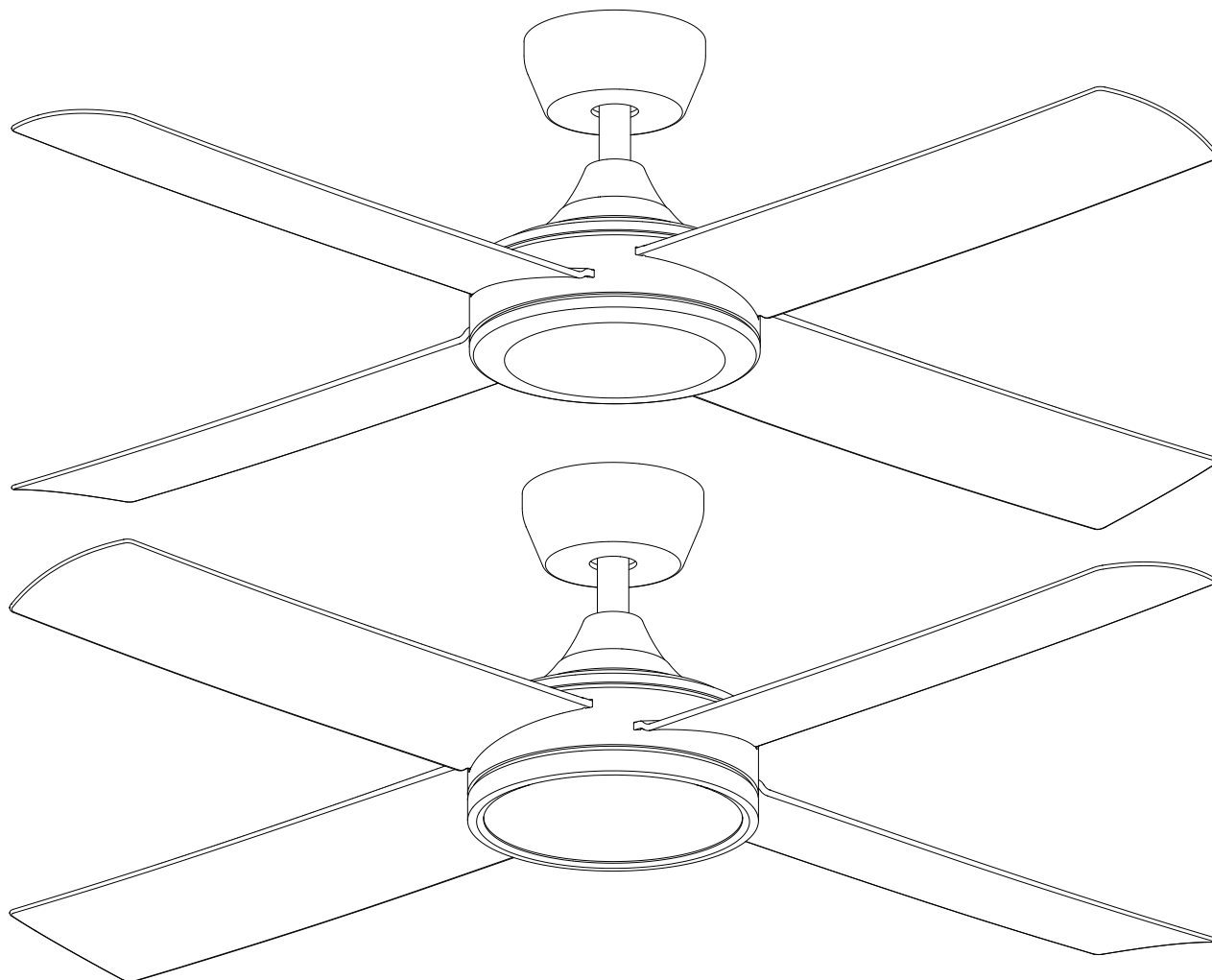

BREEZE SILENT DC PRO INSTALLATION & USER MANUAL



NOTE: THIS FAN MUST BE INSTALLED BY A LICENSED AND QUALIFIED ELECTRICIAN IN ACCORDANCE WITH LOCAL AUTHORITY REGULATIONS

ATTENTION ELECTRICIANS:

ANY PROBLEMS FOUND DURING INSTALLATION OF THE FAN PLEASE CONTACT THE NATIONAL WARRANTY NUMBER PRIOR TO LEAVING SITE.

DO NOT REMOVE THE FAN FROM THE CEILING UNLESS INSTRUCTED TO DO SO.

National Warranty Number | 07 3711 8833

Monday to Friday 9am to 5pm AEST

Thank You!

*For supporting our
Aussie owned business*

IMPORTANT INFORMATION - PLEASE READ BEFORE ATTEMPTING INSTALLATION

1. Please read these instructions carefully, be mindful of all warnings and safety information shown throughout this manual. Should you have any questions, please contact 07 3711 8833.
2. Please review the accompanying assembly diagrams before attempting installation.
3. This fan **MUST** be installed by a licensed & qualified electrician according to local authority regulations and in accordance with current wiring rules AS/NZS3000. Therefore, to protect our repair personnel, on-site warranty claims will not be accepted if products have been installed by unlicensed persons.
4. A copy of the purchasing receipt and proof of installation by a licensed and qualified electrician according to local authority regulations is required for all warranty claims.
5. Where special access equipment is required in accordance with local authority regulations all associated costs are the responsibility of the owner.
6. We reserve the right to charge a \$175 service fee for all call outs where the fan is found not to be defective and / or where access is not provided.
7. An isolation switch providing full disconnection of both fan and light must be fitted in accordance with the wiring rules (AS/NZS 60335.1 C1.7.12.2). In addition to all pole disconnection an isolation switch must be installed for each individual fan located in the same room to allow for programming and ongoing maintenance.
8. The Fan and Light (if supplied) must be earthed.
9. Your warranty will be void if a solid state dimmer or any other brand of wall or remote controller is used.
10. Installation using steel beams, grid ceilings and flexible structures are not recommended due to their inability to absorb vibration from normal operation. Timber is the recommended material to support the fan.
11. To avoid possible electric shock during installation, be sure electricity is turned off at the main power box before commencing work. Disconnect power by removing fuse or turning off circuit breaker before installing the fan. Ensure all spliced connections are adequately insulated.
12. Warning! Do not allow the rotating fan blades to come into contact with any object, this can cause serious injury or death.
13. Damage caused by; incorrect installation, Force-majeure, lightning, electrical surges & spikes, exposure to water, pests or moisture is not covered under warranty.
14. In accordance with AS/NZS60355-1 & AS/NZS60355-2-80: "This appliance is not intended for use by persons (including children) with reduced physical, sensory or mental capabilities, or lack of experience and knowledge, unless they have been given supervision or instruction concerning use of the appliance by a person responsible for their safety. Children should be supervised to ensure that they do not play with the appliance."
15. Children should be supervised to ensure that they do not play with the appliance.
16. Cleaning and user maintenance shall not be made by children.
17. Blades must be replaced only as a complete set. Blades are supplied only as a pre-balanced set and the replacement of individual blades may void the warranty by causing mechanical damage to the motor, excessive noise or premature wear.
18. Do not use outdoors where the fans could be directly exposed to water or moisture. Incorrect installation can be dangerous and will void the warranty.
19. No more than eight (8) DC fans per lighting circuit as this may cause intermittent tripping.

Please note: Minor design changes may result in slight variations between the product illustrations and the fan contained within the packaging.



Please Note: Nothing in this manual is intended to instruct or assist untrained or unqualified persons to install this product. Additionally, it is the responsibility of the installer and user to apply common sense and care at all times.

LOCATION AND INSTALLATION REQUIREMENTS

Provide adequate clearance from the floor. The lowest point on the fan blades must be at least 2.1m (7 feet) from floor level in Australia and at least 2.3m from floor level in the European Union and affiliated countries.

Make sure that the chosen location of the fan will not allow the rotating fan blades to come into contact with any objects. Ensure ceiling joists are sound and of adequate size and strength to support a 25Kg (55lb) load.

To reduce the risk of fire, electrical shock or personal injury, ensure that the fan mounting bracket is supported directly from the building structure. **DO NOT** mount to an outlet box.

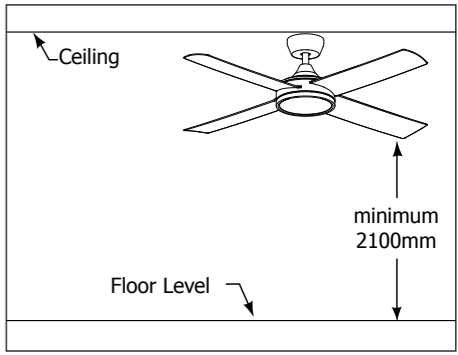

The mounting bracket must be firmly screwed to a load bearing structure e.g. a concrete ceiling, steel structure or timber frame. If a timber frame is to be added it must be securely nailed or screwed between two beams.

After the fan is completely installed, check to make sure that all connections are secure to prevent the fan from falling and/or causing damage or injury.

To reduce the risk of personal injury, do not bend or damage the motor or Fan Assembly when handling or during installation.

Please ensure special care is taken when assembling the fan. Each screw must be sufficiently tightened.



Please Note: The fan is set up for optimum airflow. To achieve the 2.1 metre floor clearance as per Australian Standards, the down rod can be cut and modified to the required length if necessary without voiding the warranty.

TABLE OF CONTENTS

Fan without light exploded diagram.....	Page 4
Fan with light exploded diagram.....	Page 5
Bracket and receiver installation.....	Page 6
Installing blades to fan motor.....	Page 7
Quick connect canopy to the mounting bracket	Page 8
Quick connect bottom cover to the motor assembly.....	Page 8
Quick connect light fixture to the motor assembly.....	Page 8
Fan remote control reprogramming.....	Page 9
How to uninstall blade (only if required for servicing).....	Page 10-11
Advanced Features.....	Page 11
Summer and Winter Mode Explained.....	Page 12
Balancing / Fan Wobble trouble shooting.....	Page 13
Safety guideline.....	Page 13
Wiring diagram (without light).....	Page 14
Wiring diagram (with light).....	Page 15
General Information.....	Page 16
General maintenance & cleaning.....	Page 16
Troubleshooting.....	Page 17
Ceiling fan warranty information.....	Page 18
Not covered by warranty.....	Page 19
Electrician Checklist.....	Page 19
Documents to retain for future warranty claims.....	Page 20

FAN WITHOUT LIGHT EXPLODED DIAGRAM

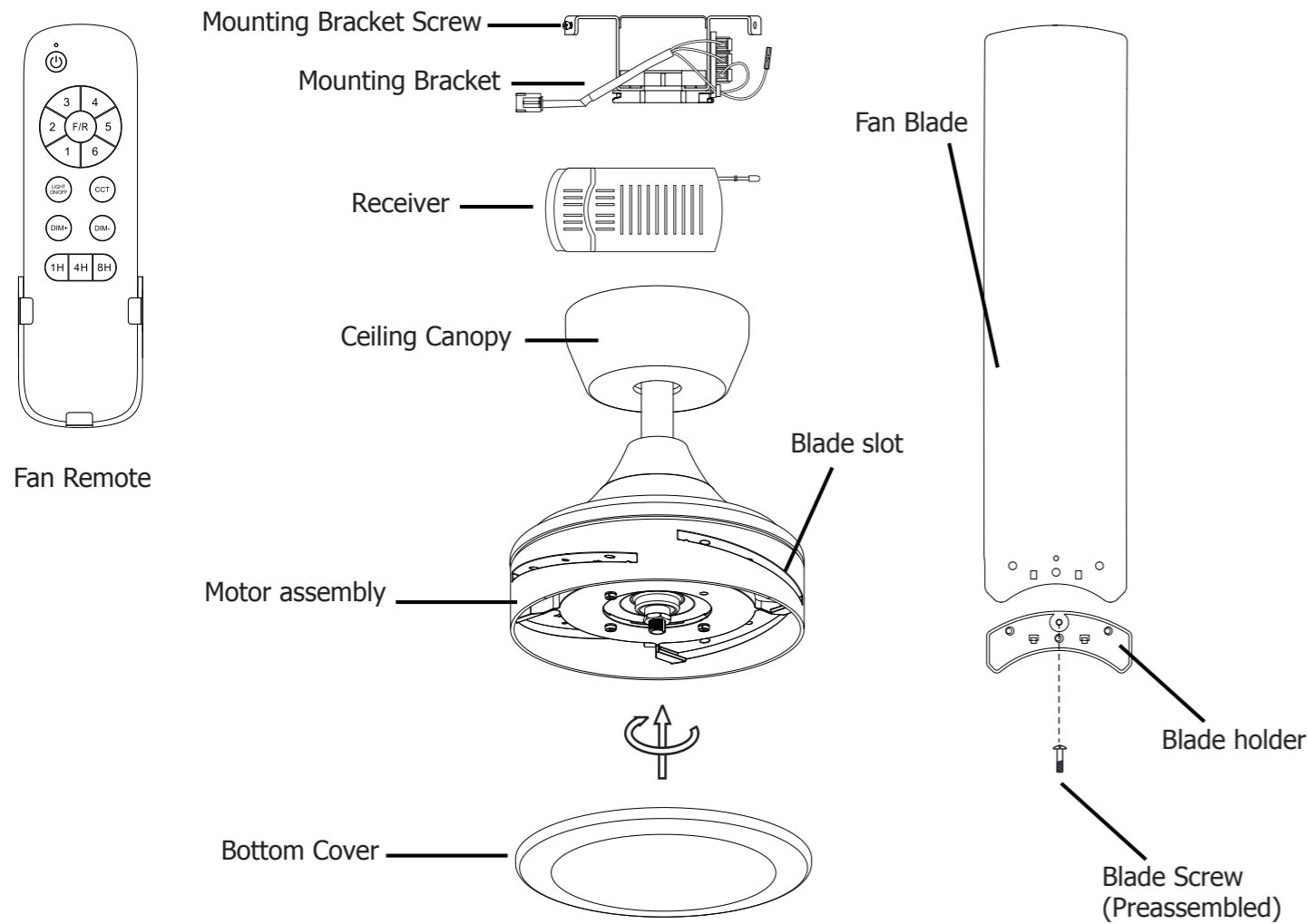

Part	Quantity	Part	Quantity
Mounting Bracket	1	Blades	4
Mounting Bracket Screw(Preassembled)	1	Blade Screws(Preassembled)	4
Motor Assembly	1	Blade holders	4
Bottom Cover	1	Remote Control	1
Remote Control Bracket	1	Receiver	1

! WARNING
 To avoid possible electrical shock, be sure electricity is turned off at the main fuse box before assembling and wiring the fan.

FAN WITH LIGHT EXPLODED DIAGRAM

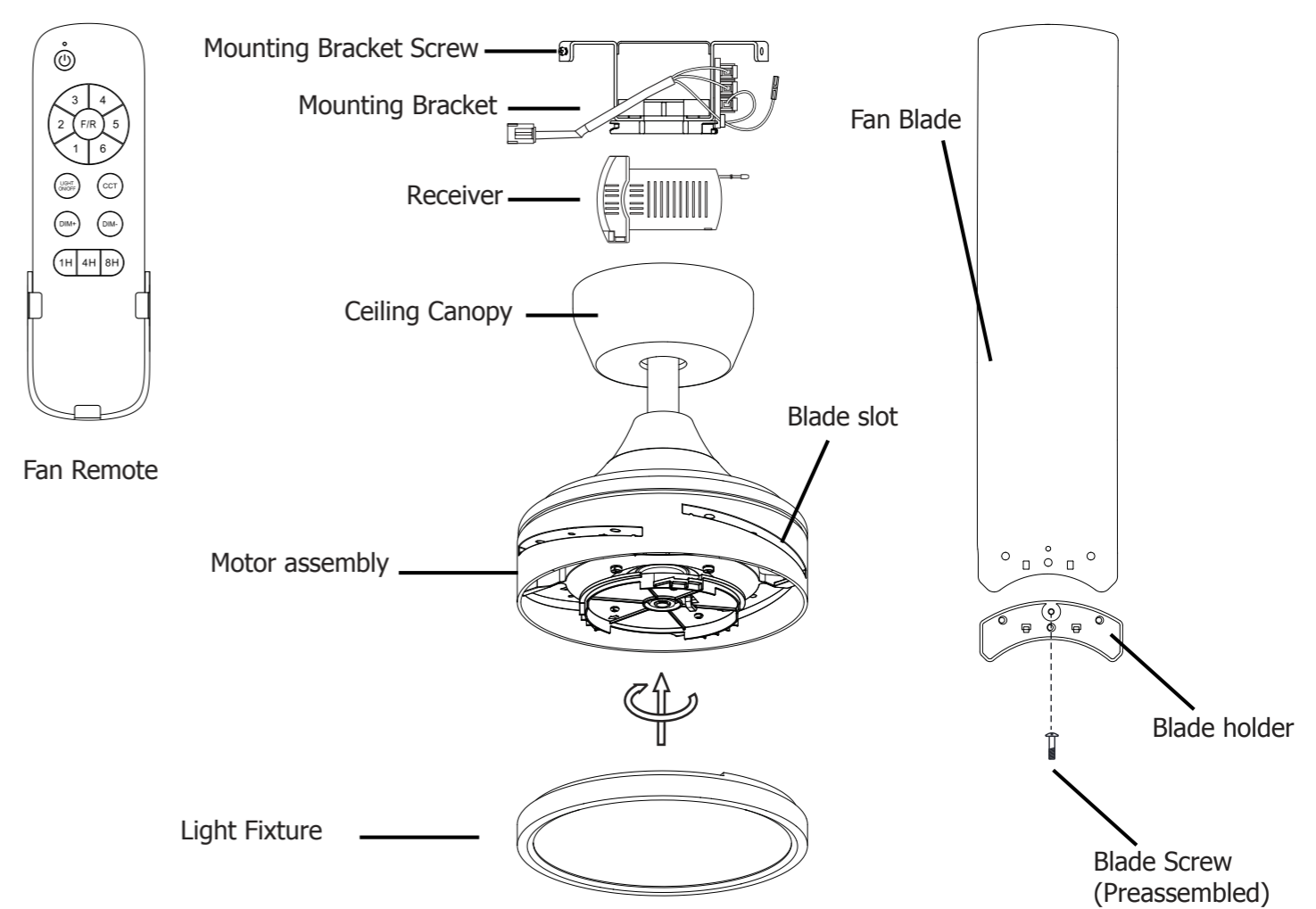

Part	Quantity	Part	Quantity
Mounting Bracket	1	Blades	4
Mounting Bracket Screw(Preassembled)	1	Blade Screws(Preassembled)	4
Motor Assembly	1	Blade holders	4
Light Fixture	1	Remote Control	1
Remote Control Bracket	1	Receiver	1

! WARNING
 To avoid possible electrical shock, be sure electricity is turned off at the main fuse box before assembling and wiring the fan.

BRACKET AND RECEIVER INSTALLATION

PLEASE NOTE: Do not use countersunk screws (bugle head) to install bracket to the ceiling. countersunk screws can allow excessive vibration causing noise issues after installation.



WARNING

THIS FAN MUST BE INSTALLED USING THE SCREWS PROVIDED - INCLUDING HANGER BRACKET SCREWS - TO BE COVERED UNDER WARRANTY.

USING BUGLE HEAD SCREWS WILL CAUSE THE BRACKET TO MOVE OVER TIME AND VOID THE WARRANTY.

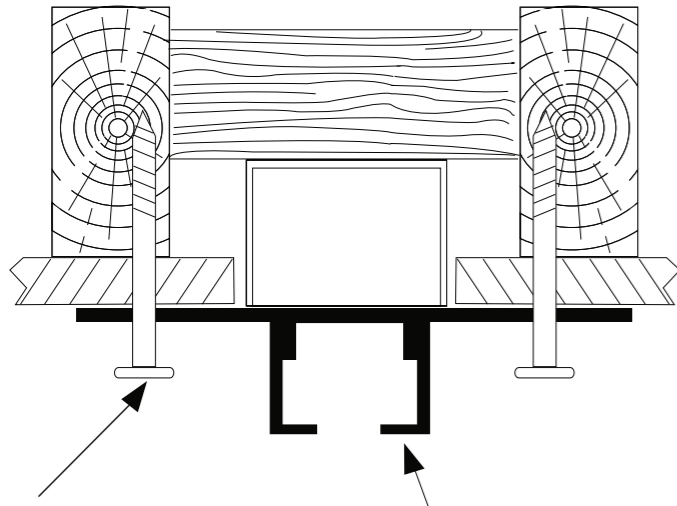

Screws
Hanger Bracket

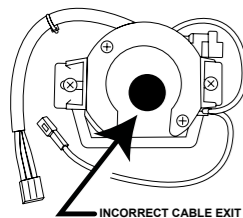

INCORRECT CABLE EXIT

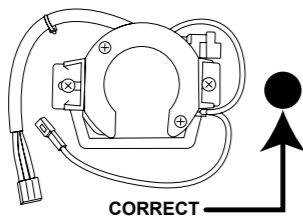

CORRECT CABLE EXIT

PLEASE NOTE: House hold wiring should exit the ceiling beside the hanger bracket not in the middle of the bracket, Do not use countersunk screws (bugle head) to install bracket to the ceiling



NOTE: Any modification to the wiring will void the fans warranty and no longer conform to Australian Standards

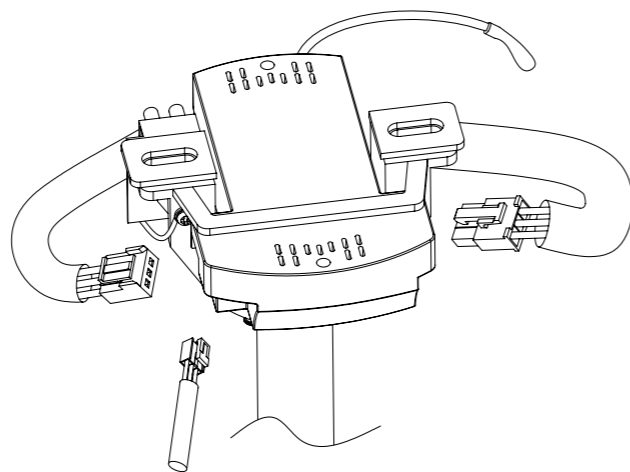
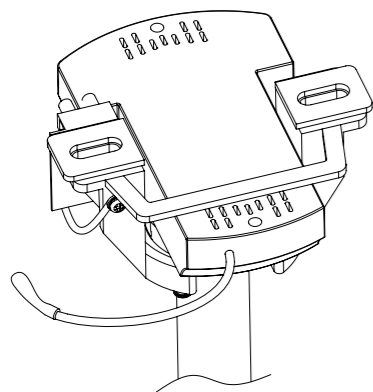

INSTALLING BLADES TO FAN MOTOR

We recommend to install the blades before hanging the fan on the ceiling.

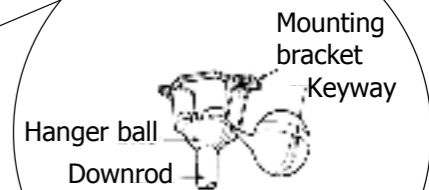
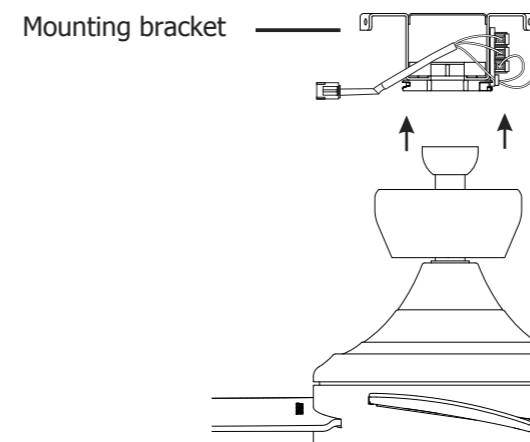
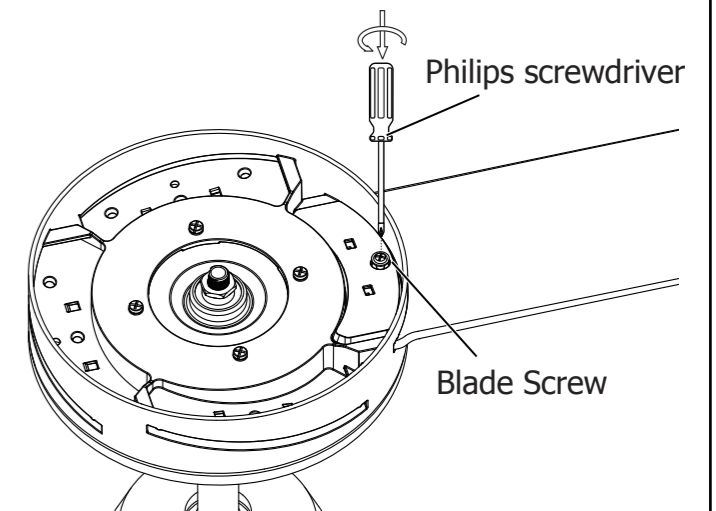
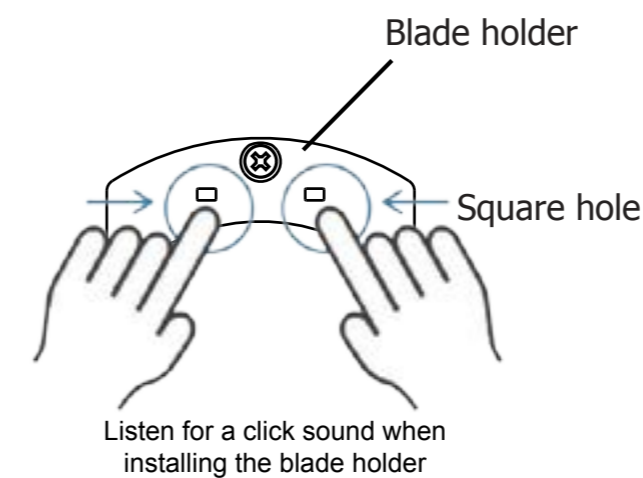
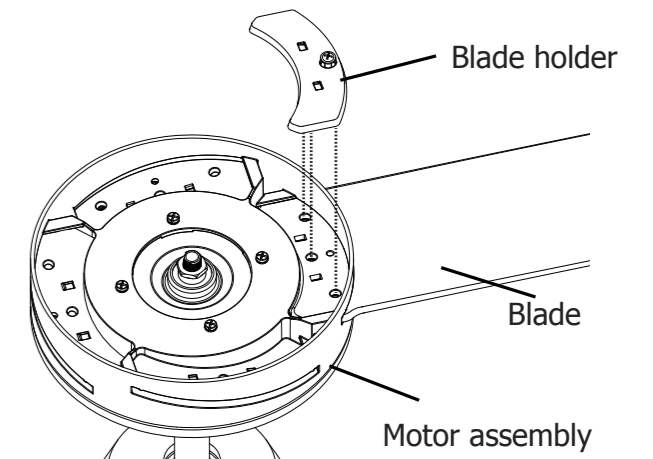
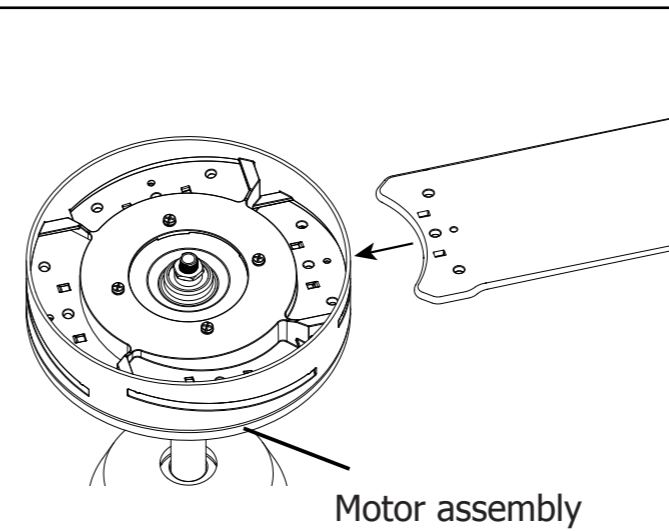

QUICK CONNECT CANOPY TO THE MOUNTING BRACKET

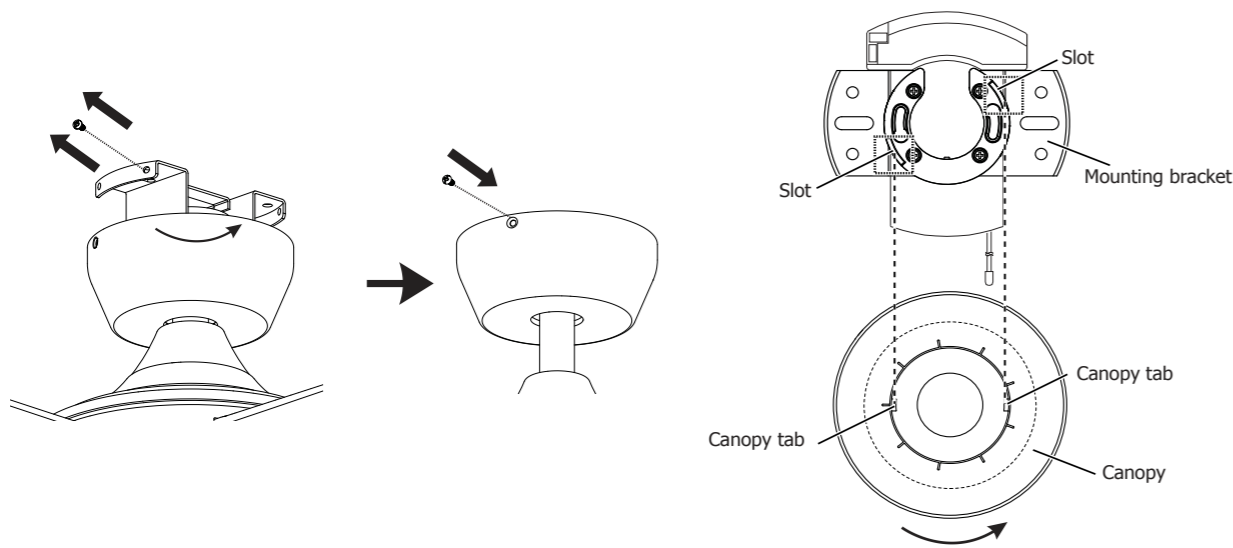

QUICK CONNECT BOTTOM COVER TO THE MOTOR ASSEMBLY

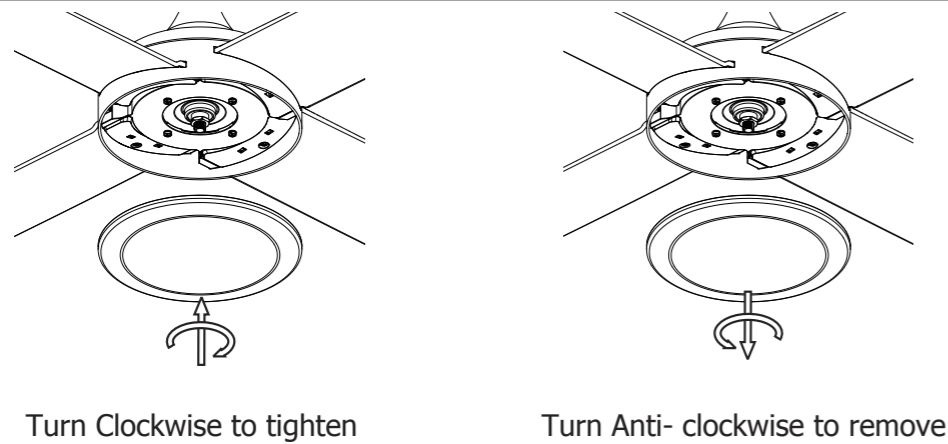

QUICK CONNECT LIGHT FIXTURE TO THE MOTOR ASSEMBLY

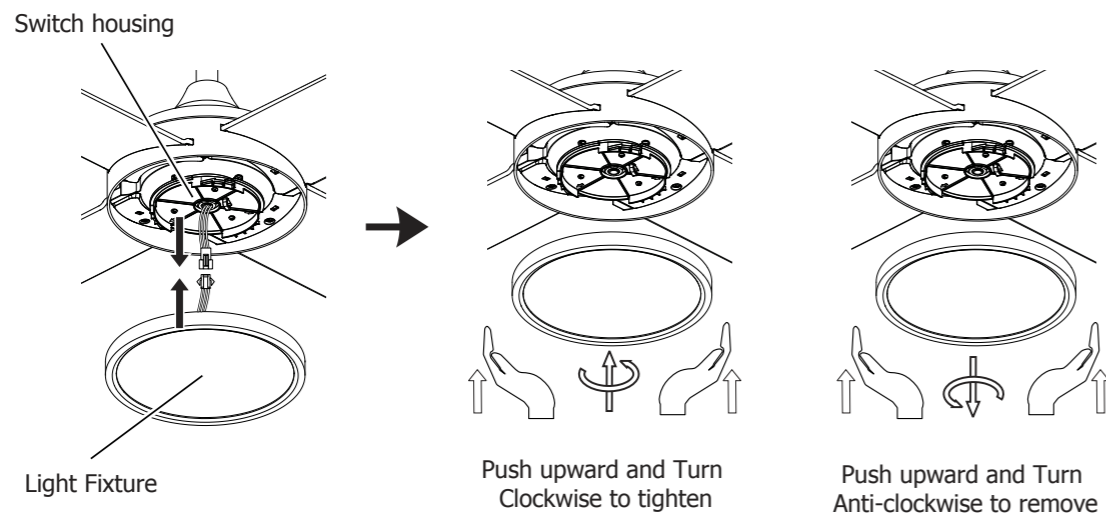

NOTE: THIS FAN MUST BE INSTALLED BY A LICENSED AND QUALIFIED ELECTRICIAN IN ACCORDANCE WITH LOCAL AUTHORITY REGULATIONS

FAN REMOTE CONTROL PROGRAMMING - OPERATING THE FAN FROM THE REMOTE CONTROL



NOTE: The Fan itself has NO DIP switches. Each individual fan must be set-up and programmed to the corresponding remote control where multiple fans are installed. If there is more than one fan please ensure the other fans remain powered off while programming.

INSTALL BATTERIES:

Locate and install the batteries, observe polarity and make sure the batteries sits properly in recess. The remote has a small indicator light which will illuminate when a button is pressed, use this to confirm the batteries are installed correctly.

REPROGRAMMING: THIS IS ONLY REQUIRED WHEN REPLACING REMOTE HANDSET

The remote comes pre-programmed to the fan and does not require following the below steps.

1. Turn off power to fan at isolation/wall switch and wait for 30 seconds.
2. Turn the power back on, the fan will beep once.
3. Press and hold the "ON /OFF" button until you hear one beep from the receiver.

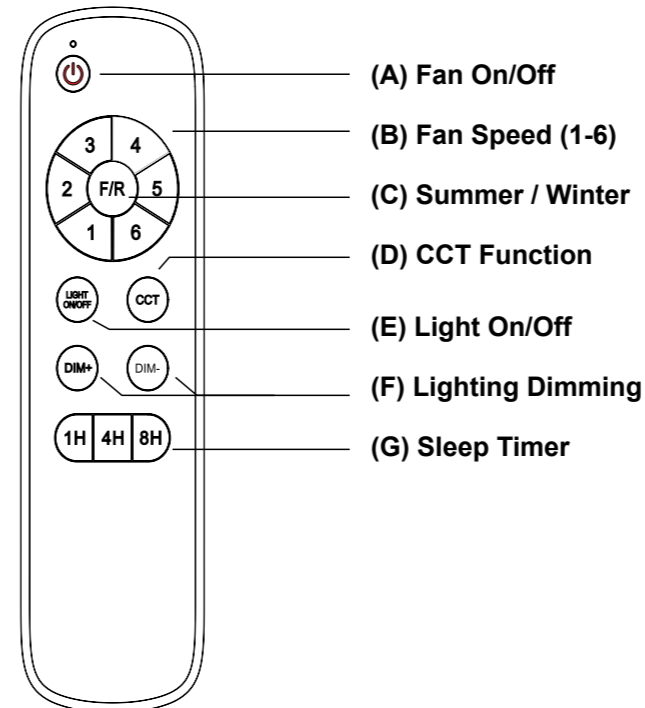

BUTTON		FUNCTION
A	Fan On/Off	Turns the fan off
B	Fan Speed (1-6)	Speed settings from 1-6, 1 being slow 6 being fast
C	Summer / Winter	Changes the rotation of the blades Summer - clockwise / Winter - counter clockwise.
D	CCT Function	To change colour, press the CCT button until the desired colour is selected. 3000K / 4000K / 6000K
E	Light On/Off	Turns the light on (with light models only)
F	Lighting Dimming	Dim the light kit up and down (with light models only)
G	Sleep Timer	Once the fan is set to a desired speed select 1Hour 4Hour or 8Hour delay timer to turn the fan off.

To turn the fan on, press the fan speed you desire

TURN OFF/ON THE REMOTE CONTROL BUZZER KEY TONE:

1. Turn off the sound: within 20 seconds of power on, press and hold the 1H timing key until the key sound is cancelled after "BEEP—".
2. Turn on the sound: If you need to restore it, please press and hold the 1H timing key within 20 seconds of powering on to restore the sound.



NOTE: The fan may start up and run on high speed, this assists with programming the fan speeds. During this time the fan remote control will not respond to the fan until the programming is complete. This is not a fault. Once the fan has completed the programming it will return to normal operation.

HOW TO UNINSTALL BLADE (ONLY IF REQUIRED FOR SERVICING)

Loosen the screw on the blade holder but no need remove the screw.

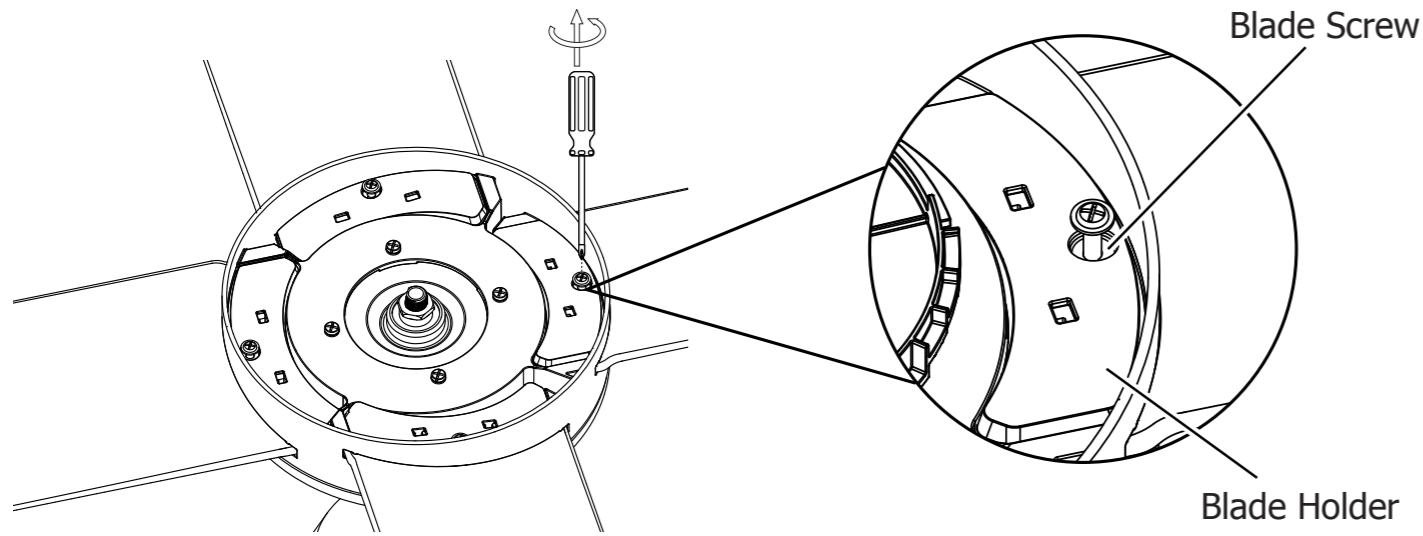

Place the screwdriver into the bottom of one of the square holes, then push it forward and backward 2 to 3 times. Do the same for the other square hole until the lock opens and the blade can be removed.

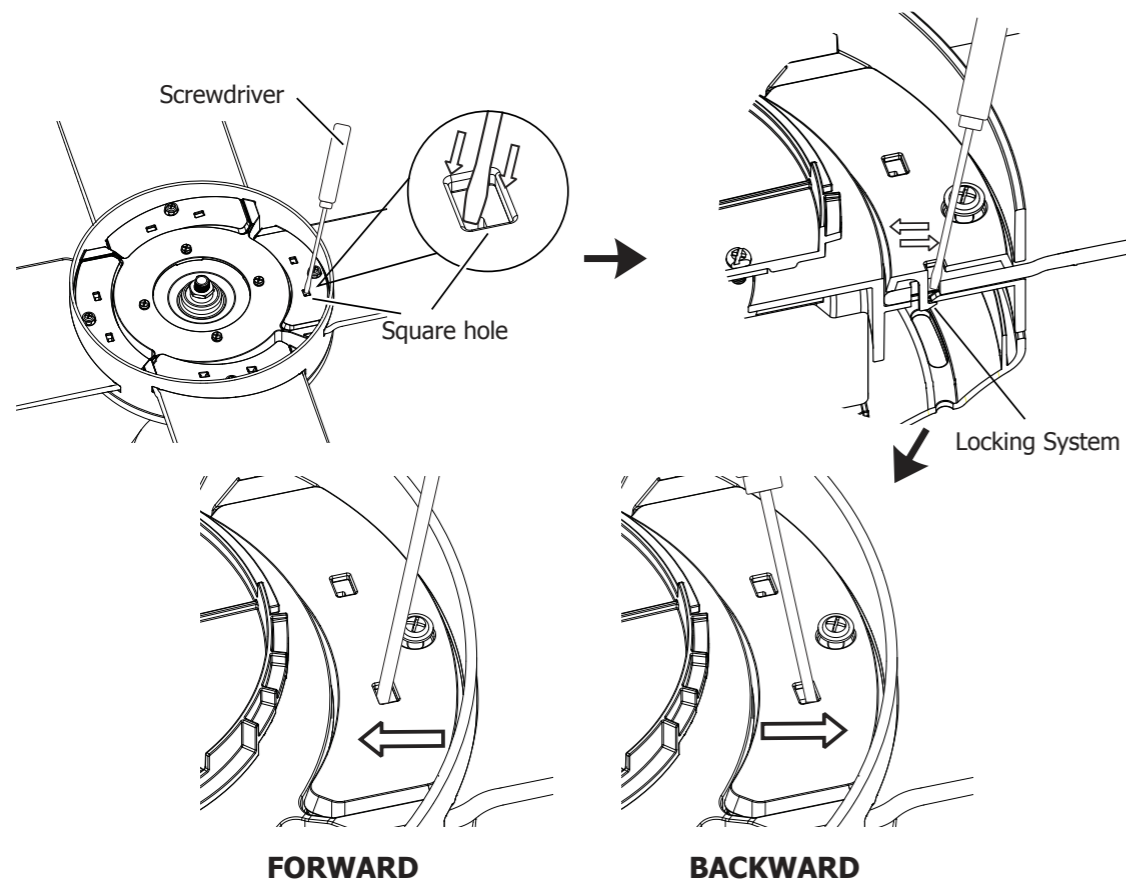

NOTE: Always use a screwdriver smaller than the square hole; otherwise, the locking system can not be opened.



HOW TO UNINSTALL BLADE (ONLY IF REQUIRED FOR SERVICING) (CONTINUED)

Loosen the screw on the blade holder but no need remove the screw.

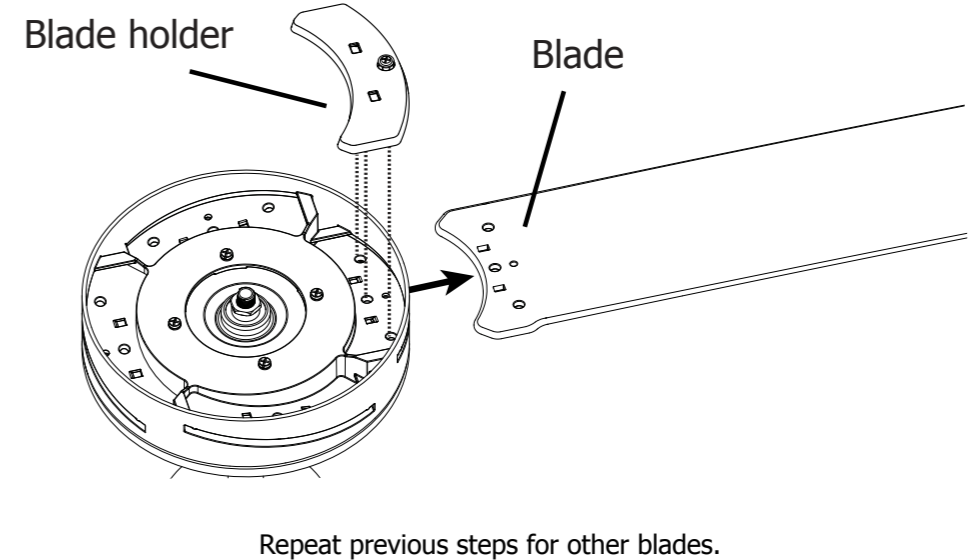

ADVANCE FEATURES

ADJUSTING POWER ON SETTINGS

There are three options for how the ceiling fan will respond to being powered by the isolation switch. When adjusting the setting, always start by turning off the power to the fan at the isolation/wall switch and wait for 30 seconds.

OPTION 1 – DEFAULT – LIGHT ON WHEN FAN IS POWERED

When ON the light will turn on when power is applied to the receiver (via an external switch or after a power failure). This allows the fan light to be turned on/off by the wall switch. The fan will not resume at the last speed. The settings can be changed by the user through the remote control handpiece as follows: Within 20 seconds of external power being turned on (isolation switch). Press and hold the speed 1 button for 20 seconds, and you will hear a beep confirmation.

OPTION 2 – RESTORE SPEED - LIGHT REMAIN OFF

When restore speed is ON the fan will resume at the same speed setting from when it was last powered by the isolation switch. The Light will remain off even if it was turned on at the time the fan was last powered. The settings can be changed by the user through the remote control handpiece as follows: Within 20 seconds of external Power being turned on (isolation switch) Press and Hold the speed 2 button for 20 seconds you will hear a beep confirmation

OPTION 3 – RESTORE SPEED - LIGHT TURN ON

When restore speed is ON the fan will resume at the same speed setting from when it was last powered by the isolation switch. The Light will also turn on even if it was turned off at the time the fan was last powered. The settings can be changed by the user through the remote control handpiece as follows: Within 20 seconds of external Power being turned on (isolation switch) Press and Hold the speed 3 button for 20 seconds you will hear a beep confirmation

SYSTEM RESET - PAIRING INSTRUCTIONS

Turn off power to fan at isolation/wall switch and wait for 30 second, within 20 seconds of turning on the power, Press and hold the 4H button the remote for 20 seconds to delete all paired remote controls and wall controls. To complete this operation, Turn off power to fan at isolation/wall switch and wait for 30 second to restart to initiate pairing mode.

REPROGRAMMING: THIS IS ONLY REQUIRED WHEN REPLACING REMOTE HANDSET

The remote comes pre-programmed to the fan and does not require following the below steps.

1. Turn off the power to the fan at the isolation/wall switch and wait for 30 seconds.
2. Turn the power back on, the fan will beep once.
3. Press and hold the "ON /OFF" button until you hear one beep from the receiver.

SUMMER AND WINTER MODE EXPLAINED

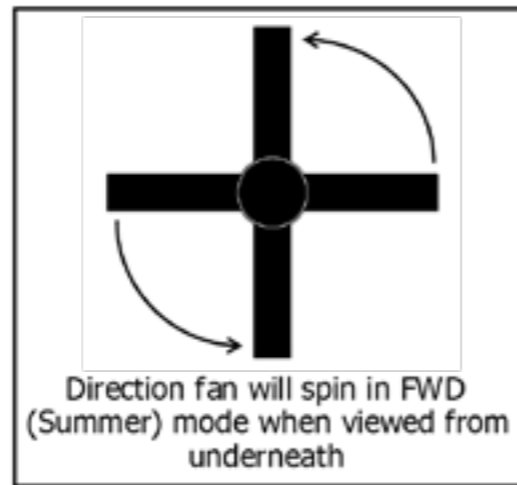
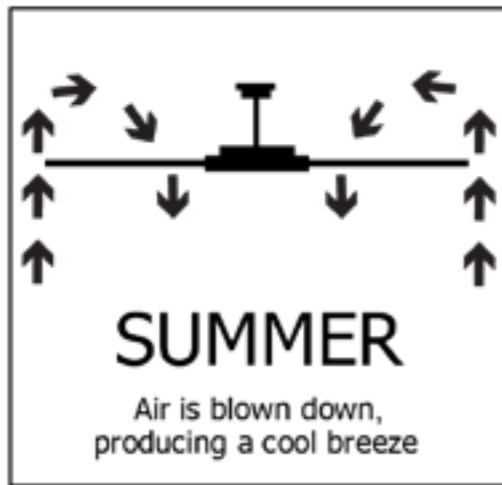

FORWARD (Summer) Mode

Ceiling fans are an environmentally smart choice to assist with cooling and warming your home.

In FORWARD (Summer) mode your ceiling fan will spin to push air down the centre of the fan producing a cooling breeze.

The direction the fan will spin in FORWARD (Summer) when viewed from underneath will be anticlockwise.

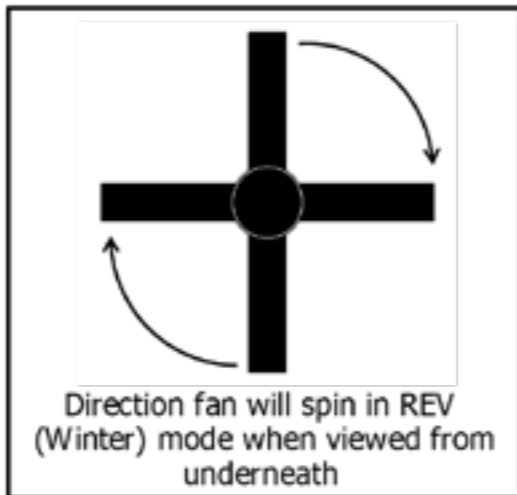
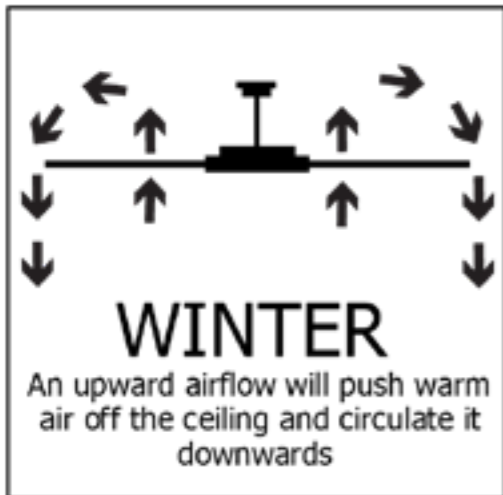

REVERSE (Winter) Mode

In REVERSE (Winter) mode your ceiling fan will spin the opposite direction. Air is drawn up the centre of the fan, and pushed along the ceiling to circulate down to the living areas.

The REVERSE (Winter) mode can also be for air circulation in a poorly ventilated rooms.

The direction the fan will spin in REVERSE (Winter) when viewed from underneath will be clockwise.



NOTE: THIS FAN MUST BE INSTALLED BY A LICENSED AND QUALIFIED ELECTRICIAN IN ACCORDANCE WITH LOCAL AUTHORITY REGULATIONS

BALANCING / FAN WOBBLE TROUBLE SHOOTING

A small amount of movement/wobble in a fan is normal and environmental factors such as open windows, exposed beams and even the shape of the room can contribute to wobble. Fans are designed to operate with wobble and will not interfere with its operation. A normal amount of movement is not considered a fault.

Steps to reduce wobble;

1. Check all blade mounting screws are done up tight and they have their washers installed.
2. Measure the tip of each blade to the ceiling if the distance is different check the blades on a flat surface to ensure they are not deformed. When re-installing blades use the same amount of pressure to tighten each screw.
3. Measure the distance from blade tip to blade tip to ensure the distance is the same between all blades. Loosen the screws on the blade holders and moves the blades back and forth until all blades are evenly spaced.

Should you try all of the above steps and find you still have a problem contact customer service for additional support.

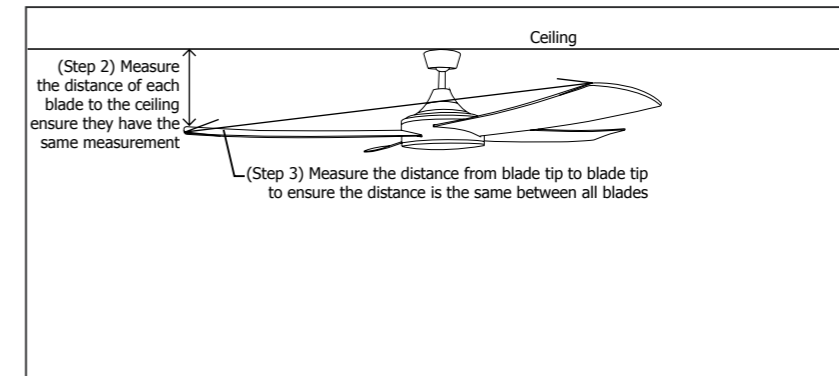

SAFETY GUIDELINE

This appliance is not intended for use by persons (including children) with reduced physical, sensory or mental capabilities, or lack of experience and knowledge, unless they have been given supervision or instruction concerning use of the appliance by a person responsible for their safety. Children should be supervised to ensure that they do not play with the appliance. (for Australia) This appliance can be used by children aged from 8 years and above and persons with reduced physical, sensory or mental capabilities or lack of experience and knowledge if they have been given supervision or instruction concerning use of the appliance in a safe way and understand the hazards involved. Children shall not play with the appliance. Cleaning and user maintenance shall not be made by children without supervision. (for EU)

Means for disconnection must be incorporated in the fixed wiring in accordance with the wiring rules. The fan is to be installed so that the blades are more than 2.1 m above the floor. (for Australia) The fan is to be installed so that the blades are more than 2.3 m above the floor. (for EU)

WARNING: If unusual oscillating movement is observed, immediately stop using the ceiling fan and contact the manufacturer, its service agent or suitably qualified persons. The replacement of parts for the safety suspension system device shall be performed by the manufacturer, its service agent or suitably qualified persons. The mounting of the suspension system shall be performed by the manufacturer, its service agent or suitably qualified persons;

- The fixing means for attachment to the ceiling such as hooks or other devices shall be fixed with a sufficient strength to withstand 4 times the weight of the ceiling fan; The light source contained in this luminaire shall only be replaced by the manufacturer or his service agent or a similar qualified person.

WIRING DIAGRAM (WITHOUT LIGHT)

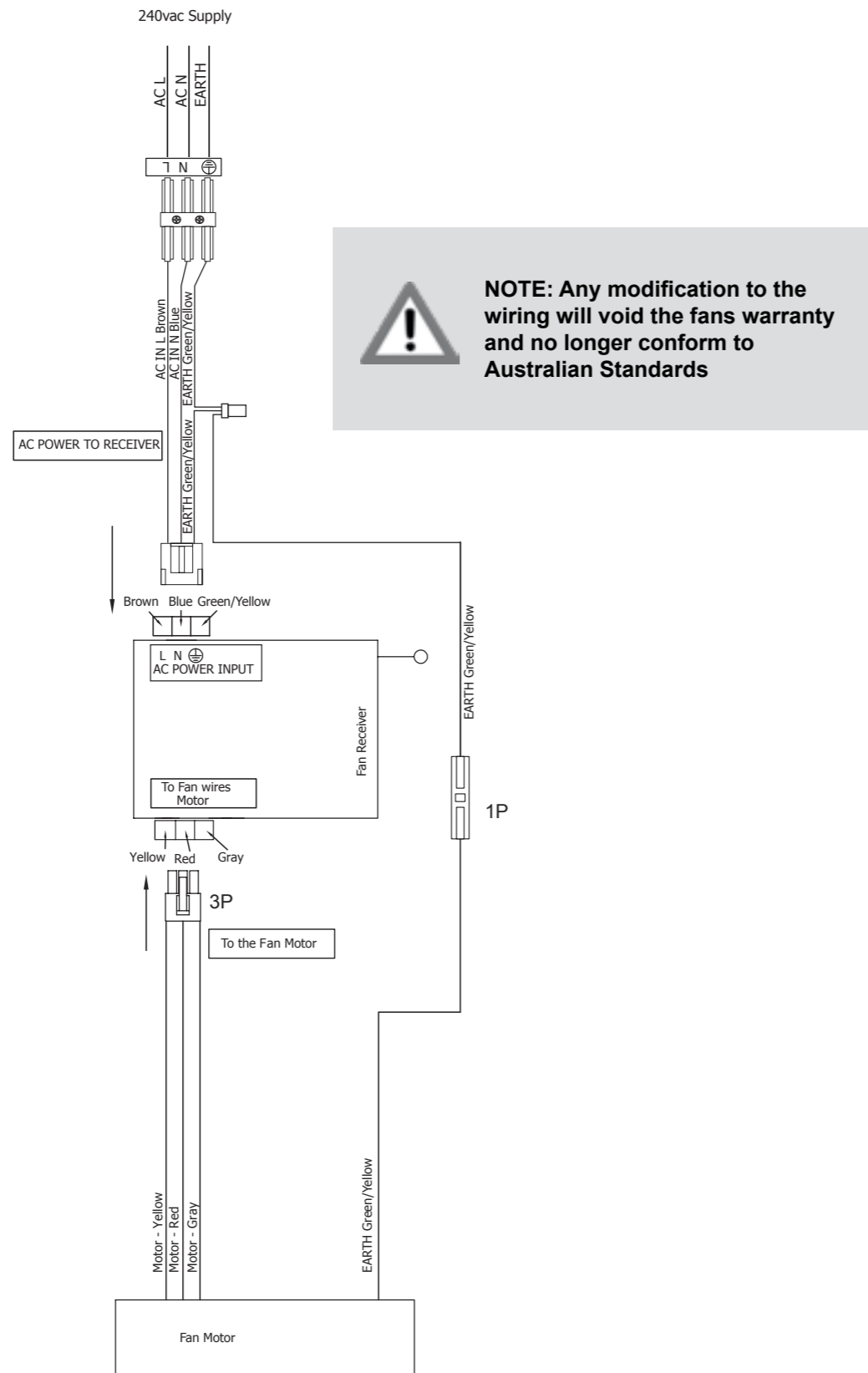

NOTE: Any modification to the wiring will void the fans warranty and no longer conform to Australian Standards

DANGER Before commencing installation, turn off electricity at the main power box or disconnect power by removing fuse or turning off circuit breaker. This fan must be installed by a licensed and qualified electrician in accordance with local authority regulations.

WIRING DIAGRAM (WITH LIGHT)

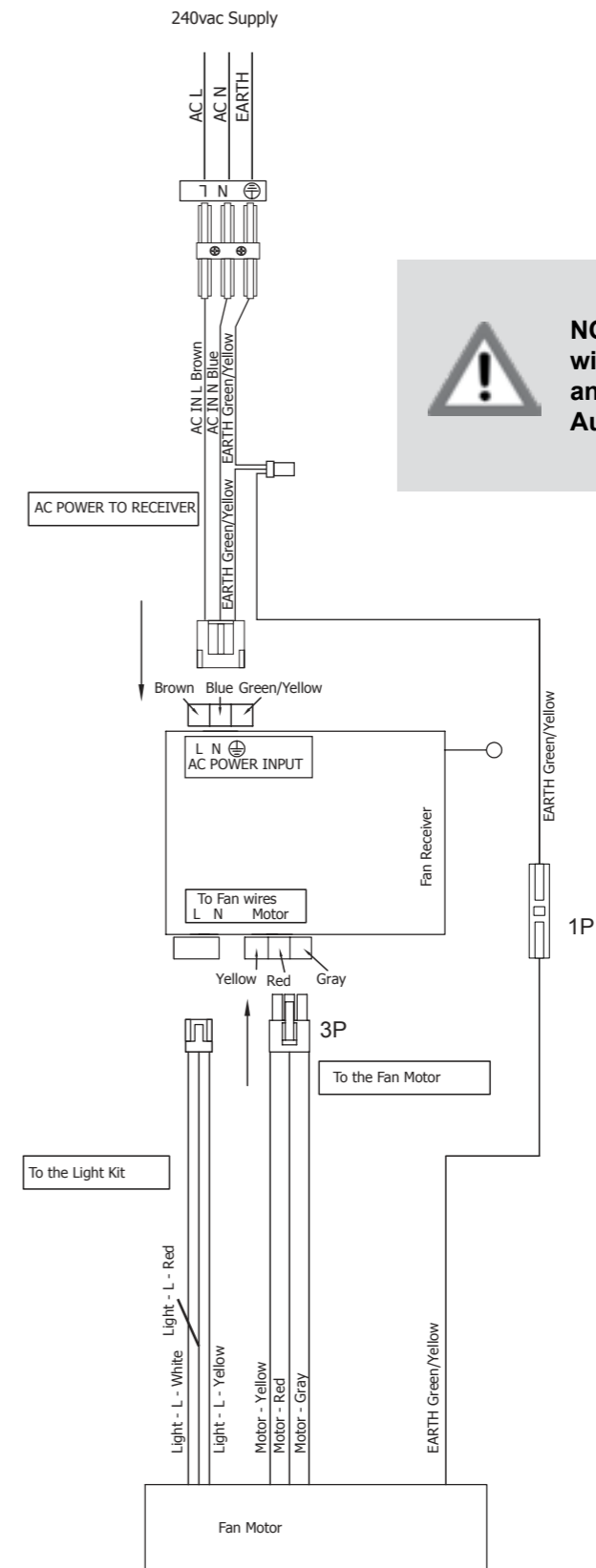

NOTE: Any modification to the wiring will void the fans warranty and no longer conform to Australian Standards

DANGER Before commencing installation, turn off electricity at the main power box or disconnect power by removing fuse or turning off circuit breaker. This fan must be installed by a licensed and qualified electrician in accordance with local authority regulations.

GENERAL INFORMATION

1. All electrical motors, including fan motors make some noise, and may feel hot to the touch. This is NOT a fault.
2. Ceiling fans tend to move during operation due to the fact that they are not rigidly mounted. (Rigid mountings can generate excessive vibration and stress on the mountings). Movement of a couple of centimetres is quite OK and does not suggest that the fan will fall down. The fan is mounted securely on a metal Hanger Bracket with rubber cushioning and a ball joint to allow free movement. Please note that due to manufacturing variations not all ceiling fans are exactly the same some may move more than others.
3. Ceiling fans are an environmentally smart choice to help cool you in your home. They work by creating air flow which causes a cooling sensation on the skin. The faster the speed of the air flow, the greater the cooling sensation. Ceiling fans do not work by cooling the room, so they should be switched off when there is no one in the room, to save energy. The effectiveness of ceiling fans is also dependent on the humidity in the air they are more effective in humid environments, and less so in dry ones.
4. During winter, a reverse turning fan helps to reduce heating costs. Warm air rises to the ceiling, where it cannot be felt by the occupants of a room, especially in areas with high ceilings. The fan helps to keep warm air away from the ceiling, and mixes it with the air below.

GENERAL MAINTENANCE & CLEANING

* Before maintenance ensure fan is switched off at the isolation switch or circuit breaker *

Changing Remote Batteries

Batteries used in Handsets will weaken over time and should be replaced every 6 months. Batteries removed from the handset should be disposed of properly and kept out of reach of children.

Cleaning the Motor Housing

Motor housings should be cleaned every 3 to 4 months to avoid build up of dust. Dust will attract moisture and condensation leading to corrosion. Use a soft, damp (not wet) cloth to remove dust. Use only water and mild detergent. Spray cleaners may damage coatings.

Cleaning the Blades

Use a soft damp cloth to remove dirt from blades. Always dry blades after cleaning. Blades should not be left damp or wet as this will damage blade finish or cause corrosion. Use only water and mild detergent. Spray cleaners may damage coatings. Always use soft cloths to clean blades and motor housings to avoid scratching painted and plated finishes. Ideally your fan should be cleaned every 3 to 4 months. If removing blades for cleaning then do so for each fan separately, do not mix blades from different fans as this can upset the balance of the fan. Put blades back in the position they came from.

Normal Wear and Tear

Please note that a ceiling fan travels an enormous distance in the course of its normal operation. Air is abrasive and suspended dust, high humidity and other contamination will cause wear and tear of surfaces.

The use of fans under roofed decks and pergolas next to swimming pools and in coastal areas will require increased maintenance due to the presence of chlorides (either as common air borne salt spray or from compounds in pool chemicals) The temperatures attained in the peak of a pitched deck or veranda roof can easily exceed 60-70°C and especially when coupled with chlorides this will increase maintenance requirements. Even indoors in coastal areas the influx of warm, sea air can accelerate the surface corrosion of metal parts. This can still happen many kilometres from the sea.

When humidity is high and temperature drops moisture condenses on metal surfaces including ceiling fans. The layer of moisture can be almost microscopic but it will affect the surface by depositing a tiny layer of dissolved salts or airborne acidic compounds and thus eventually leading to corrosion if the product is not properly and regularly cleaned. This applies equally to indoor and outdoor fans.

LACK OF MAINTENANCE LEADING TO SURFACE CORROSION OR SIMILAR DAMAGE IS NOT COVERED BY WARRANTY.



TROUBLESHOOTING

PROBLEM	POSSIBLE CAUSES	PROBABLE SOLUTIONS
Fan does not power up. <i>(Warning: The ceiling fan must be switched OFF and the assistance of a licensed electrician may be required.)</i>	No mains voltage going to fan.	Check the dwelling's fuse/box circuit breakers has not failed / tripped and check that 240V is available at the Terminal Block
	Isolation switch turned off.	Check isolation switch is turned on.
	Loose Connection	Check all fan wiring is firmly in place and connectors locked in. Disconnect and reconnect all connectors.
Fan is not responding to the remote control.	Batteries in the remote control flat	Change the Batteries in the remote control - always install brand new batteries (not lithium).
	Fan not programmed properly	Check that the handset has been programmed to the receiver (refer to page 8)
Fan Wobbles. <i>(Warning: The ceiling fan must be switched OFF and the assistance of a licensed electrician may be required.)</i>	Hanger ball is loose in hanger bracket	Check the hanger ball is locked into the hanger bracket groove
	Blades not a matching set	Check each blade to make sure that the weights are the same. (there is a 5gm buffer)
	Loose Screws	Check all screws are tight - be careful to never over tighten the screws.
	Loose Hanger Bracket	Check that the bracket is tight against the ceiling and the ceiling and ceiling structure is not moving.
	Countersunk screws have been used	Countersunk screws will make the fan wobble and eventually allow the bracket to move. Replace Countersunk screws with screws that have been supplied with the fan.
	Environmental	See page 11 for further steps.
Fan is noisy <i>(Warning: The ceiling fan must be switched OFF and the assistance of a licensed electrician may be required.)</i>	Loose Screws or Parts	Check all screws and parts are secured firmly - be careful to never over tighten the screws. Ensure there are no loose parts moving inside the motor housing.
	Hanger Bracket could be loose	Check that the ceiling bracket is secure.
	Requires running in	Allow fan to run for at least 8 hours to settle in.
Light does not turn on. <i>(Warning: The ceiling fan must be switched OFF and the assistance of a licensed electrician may be required.)</i>	No power to the fan.	Check circuit breakers / Fuses / isolation switch.
	Loose wire in light assembly.	Check wires in light kit assembly.
	Issue with the remote control.	Refer to above issues pertaining to the remote control for a solution.
Fan does not move much air	The fan is in winter mode.	Using the remote control change the fan from winter (reverse) to summer mode.

CEILING FAN WARRANTY INFORMATION

This warranty applies only to Australian states and its mainland territories. The benefits of this warranty are in addition to any rights offered under state or territory law.

Please also note the following, prior to requesting service, please consult the Troubleshooting section in the manual;

1. All electric motors, including fans, make some noise and may feel hot to touch – this is not a fault.
2. Some fans wobble more than others – even the same model.
3. Blades are weighed to be within tolerance to minimise wobbling. In multiple installations do not mix blades from fans.
4. Fan lights can rattle and are not covered by warranty.
5. Blade, remote control and light shade replacements are not covered by in home servicing.

This product warranty excludes to the extent possible under law any liability for consequential loss or damages directly or indirectly resulting from a faulty ceiling fan or accessory product that is not installed or maintained according to the installation instructions. When installed, maintained and used according to the instructions such loss or damage can be easily avoided or minimised.

This statement is required by the Australian Consumer Law: "Our goods come with guarantees that cannot be excluded under the Australian Consumer Law. You are entitled to a replacement or refund for a major failure and for compensation for any other reasonably foreseeable loss or damage. You are also entitled to have the goods repaired or replaced if the goods fail to be of acceptable quality and the failure does not amount to a major failure."

MAKING A CLAIM

You must have the original purchase receipt or bill of sale along with a proof of installation by a Licensed Electrician to make a warranty claim. No claim will be accepted without these documents being provided. Please contact Calibo via the warranty hotline, web or email.

Please note carefully - If the product is found to be free of defects or the product is not functioning properly as a result of faulty installation or lack of maintenance then Calibo or its service agent reserve the right to charge a service fee to rectify the reported problem.

CEILING FAN WARRANTY PERIOD.

The ceiling fan itself, excluding the Remote Control Transmitter and Receiver, is covered by a 2 year in home warranty. During this period, Calibo will, at its discretion, repair or replace defective product. Labour and product delivery costs are borne by Calibo during this 2 year period. The cost of obtaining or using special access equipment (scissor lifts, scaffolding etc.) is specifically excluded, and it is the responsibility of the owner to provide such equipment and have it safely installed and operated.

REMOTE CONTROL WARRANTY PERIOD.

In general, Calibo Remote Controls and Receivers are covered by a 1 year in home warranty under the same conditions as described above.

BALANCE OF WARRANTY ON REPAIRED OR REPLACED PRODUCTS.

Any replaced or repaired product is covered only by the balance of the warranty remaining on the original article.

TRANSFER OF WARRANTY.

If the dwelling where the fan or remote control is installed changes hands, the balance of the warranty passes to the new owner, providing the original bill of sale and proof of installation by a Licensed Electrician for the product is retained by the new owner.

Warranty for the fan does not cover damage to the fan if it is moved from one dwelling to another during the warranty period. The warranty is voided in total if the product is sold as second hand goods.



NOT COVERED BY WARRANTY

1. Any damage incurred after delivery to the owner that is not caused by a fault in the products materials or workmanship; damage from lightning or power surges; incorrect installation; damage due to incorrect installation; noise or other influence of ripple control or information access systems operated over power delivery infrastructure; water damage of any kind; installation or use outdoors; damage arising from connection to or use with alternative power systems (e.g. inverters, solar, etc.).
2. Interference from other devices operating on the same frequency. This issue can be overcome by reprogramming the remote control hand piece to the Fan. A mechanism to isolate power is highly required, this will remove the requirement to engage a licensed electrician to complete the programming steps.
3. Ceiling fans not installed by a licensed and qualified electrician in accordance with local authority regulations.
4. Incorrect operation of the ceiling fan, accidental damage, modification in any way or not servicing in accordance with the maintenance instructions.
5. Travelling costs incurred by Calibo personnel or service agents exceeding 30kms between the nearest agents' service depot and the customer. These costs must be met by the purchaser.
6. Subject to any statutory provisions to the contrary, claims for damage to furniture, carpet, walls, ceilings, foundations or any other consequential loss either directly or indirectly resulting from a faulty ceiling fan.
7. Ripple Control signals sent through the mains power supply by the electricity supplier for off peak hot water, and other signals including those for street lights and such. These signals may cause an intermittent humming in the ceiling fan. It is not the fault of the ceiling fan.
8. When humidity is high and temperature drops moisture condenses on metal surfaces including ceiling fans. The layer of moisture can be almost microscopic but it will affect the surface by depositing a tiny layer of dissolved salts or airborne acidic compounds and thus eventually leading to corrosion if the product is not properly and regularly cleaned.
9. A service call fee will be charged where; there is nothing wrong with the ceiling fan or; the defective operation of the ceiling fan is due to failure of electricity or; the installation is not in accordance with Calibo instructions and/or applicable local regulations or; the defects have been caused by incorrect application or abuse of the ceiling fan or; the damage has been caused by unauthorised persons attempting to repair the fan

ELECTRICIAN CHECKLIST

Electricians make sure everything on this checklist is ticked off before you leave the installation site. If you have trouble installing our product please refer to the trouble shooting section on page 11 first, then phone the Calibo Warranty Hotline on 07 3711 8833 (open 9am to 5pm EST). DO NOT uninstall the fan unless asked to do so.

1.	Ceiling fan is not installed using a solid-state wall controller. Wall controllers must only be types approved for use by Calibo.	
2.	The fan, fan light assembly and bracket are earthed.	
3.	Fan, fan light and remote control receiver are run from the same final circuit via an isolation switch.	
4.	Mounting bracket must be firmly secured to a solid structure such as a concrete ceiling, steel structure or timber framing. If additional bracing is added it must be firmly secured to the rafters and not left floating on the ceiling.	
5.	Counter sunk screws are not to be used to attach bracket to ceiling.	
6.	Fan blades are at least 2.1m (7 feet) above floor level.	
7.	Check the fan is operating correctly on all speeds.	
8.	If light is installed. Check light is functioning properly.	

National Warranty Hotline: 07 3711 8833

Monday to Friday 9am to 5pm AEST

DOCUMENTS TO RETAIN FOR FUTURE WARRANTY CLAIMS

TO ASSIST WITH ANY WARRANTY CLAIMS ATTACH THE FOLLOWING DOCUMENTS FOR FUTURE REFERENCE.

1. Copy of the Purchasing Receipt.
2. Proof of Professional Installation - in-accordance with local authority Regulations (copy of installation Invoice, Safety Certificate or letter on Letter head including licence details)



NOTE: THIS FAN MUST BE INSTALLED BY A LICENSED AND QUALIFIED ELECTRICIAN IN ACCORDANCE WITH LOCAL AUTHORITY REGULATIONS

Distributed by

EM Imports Pty Ltd
10 Overlord Place
Acacia Ridge Queensland
Australia 4110

Warranty & Support:
Calibo
Ph: 07 3711 8833
support@calibo.com.au

Thank You!

*For supporting our
Aussie owned business*